

Hurricane[®] S2 Turbine Ventilator

Refer to product table below for applicable product codes covered by this document

Issue **D**

Product Type & Application

The Bradford Hurricane[®] S2 is a wind-driven turbine ventilator designed to ventilate buildings in moist and dusty environments in non-BAL regions.

Compliance with the NCC

For use in Australia, when correctly specified and installed, this product provides the following compliance:

NCC2022

- **Weatherproofing** - Meets the requirements of the NCC 2022 Volume 1 Amend. 2 Weatherproofing Performance Requirement F3P1 via Deemed-to-Satisfy (DtS) and performance solution pathways.

NCC2019

- **Weatherproofing** - Meets the requirements of the NCC 2019 Volume 1 Amend. 1 Weatherproofing Performance Requirement FP1.4 via Deemed-to-Satisfy (DtS) and performance solution pathways.

Evidence of Suitability

- Weatherproofing -
 - Excelo Consulting Engineers Performance Solution Report ECE24168 Commercial.ECE24168.

Conditions of Storage, Use & Maintenance

- Store in the original packaging in a cool and dry area.
- Top load only – damage may be caused to ventilator by stacking other items on top of the packaging and/or ventilator.
- Do not attempt to repair – contact Bradford Ventilation for service advice.
- This product requires regular inspection and maintenance, which should be increased in frequency when used in harsh environments.

Refer to the product warranty at bradfordventilation.com.au for more information.

Specific Design or Installation Instructions

- **Caution:** The turbine head of this product can rotate without warning (even during installation) – always keep body parts away from moving components.
- This product requires specific areas to be sealed against water entry and other areas to be left unsealed to allow internal condensation drainage – refer to the installation guide for details.
- This product may be used in dusty or moist applications in conjunction with a regular inspection and maintenance program. Refer to the installation guide for details.
- The table below shows the minimum make-up air requirement per ventilator that should be provided in accordance with AS1668.2

Product	Make-Up Air per ventilator - 100% open, evenly distributed open area
Hurricane [®] 100-400	≥ 0.3m ²
Hurricane [®] 450-600	≥ 0.5m ²

- Make-up air ingress should be provided via evenly distributed openings which are permanently open and positioned to help the ventilator work more effectively and efficiently (refer to the product installation guide for guidance).
- If make-up air is insufficient the ventilators will draw make-up air from each other. This will diminish the system effectiveness - air will be drawn inward through ventilators which are meant to be exhausting air. It will also increase the risk of drawing external water into the building during periods of rain. Further to this, it is recommended that ventilators of the same size are used together to prevent make-up air being drawing between ventilators of different sizes.
- The rotating head of this product must be installed horizontally to ensure correct operation – adjustment of the varipitch and base flashing is critical to achieve this orientation (refer to the installation guide for details).
- If the product is installed with a stainless-steel mesh, it should be periodically inspected to remove foreign objects and/or dust build-up to maintain airflow.
- The size of the ventilator should be selected based upon the available roof area and required airflow performance.

For general installation guidance refer to the product installation guide at www.bradfordventilation.com.au

Hurricane[®] S2 Turbine Ventilator

Limitations of Use

- **IMPORTANT** - Do Not Modify This Product: Compliance with the evidence of suitability data referenced in this document is only achieved by the product or configuration listed in this PTS.
- Do not use for exhausting hazardous, abrasive, acidic and alkaline vapour or areas containing explosive or corrosive materials.
- This product is not suitable for use within 500m of a saltwater body.
- Products installed in harsh environments are recommended to be specified with (optional) polyolefin or powder coat finish for additional corrosion protection.
- This product has not been tested for, and is not suitable for use in cyclonic wind regions C or D.
- This product is not sealed and therefore not suitable for the containment of smoke, preventing air entry or isolation of specific volumes of air.
- This product is not suitable for use in Bush Fire BAL-12.5 to BAL-40 or BAL-FZ rated areas.
- The optional stainless-steel mesh available for use in this product as an insect guard does not comply with BAL requirements.
- Product flow rate will be reduced if stainless steel mesh is not adequately maintained.
- Seek technical advice from Bradford Ventilation on application suitability if unsure.

Hurricane® S2 Turbine Ventilator

Applicable Product Codes (SKU)

Hurricane® 100mm	Hurricane® 150mm	Hurricane® 300mm	Hurricane® 400mm
Custom 601150#	Custom 601162#	Custom 600670	Custom 600671

Product discontinued July 2025.

Product Specifications (in exploded view)

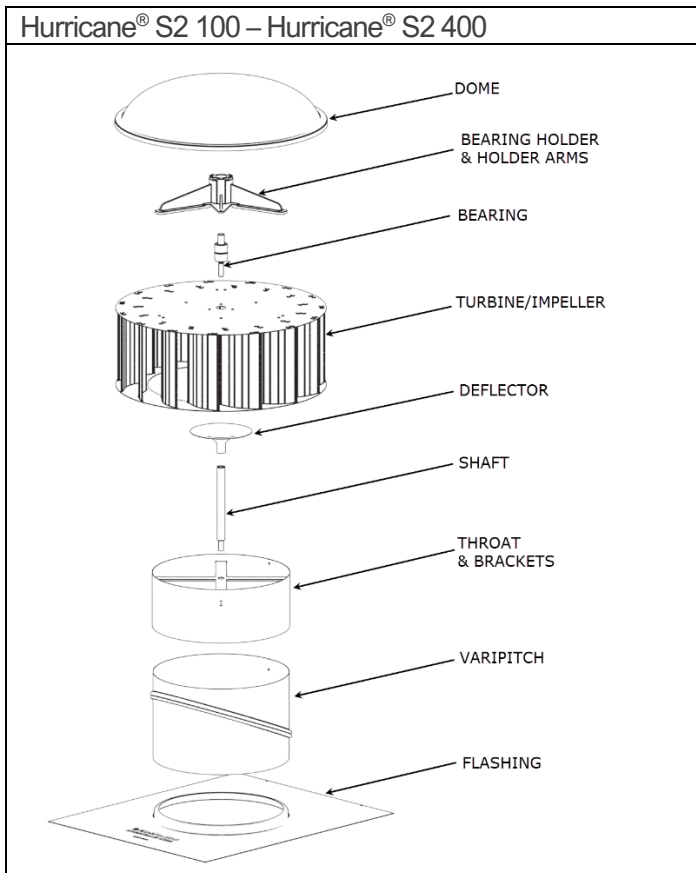

Product Information Summary S2 100 / S2 150 / S2 300 / S2 400

Ventilator Range	Hurricane® S2			
	S2 100	S2 150	S2 300	S2 400
Ventilator Model	S2 100	S2 150	S2 300	S2 400
Ventilator Type (AS/NZS 4740:2000 cl 1.5)	Type 4 – Rotating Wind-Driven Roof Ventilator			
Ventilator Performance Class (AS/NZS 4740:2000 Table 1.2)				
Effective Aerodynamic Area, EAA	0.003 m ²	0.009 m ²	0.044 m ²	0.082 m ²
Discharge Coefficient, C _d	0.539 - Class 2	0.529 - Class 2	0.712 - Class 1	0.731 - Class 1
Flow Coefficient, C _f	0.2 - Class 4	0.21 - Class 4	0.27 - Class 3	0.24 - Class 4
Nominal Performance* (m ³ /h)				
0 m/s	25 m ³ /h	76 m ³ /h	375 m ³ /h	699 m ³ /h
3 m/s	26 m ³ /h	79 m ³ /h	397 m ³ /h	742 m ³ /h
6 m/s	28 m ³ /h	87 m ³ /h	457 m ³ /h	857 m ³ /h

*In accordance to AS/NZS 4740:2000 nominal performance parameters where h = 6m, ΔT = 14°C, T = 20°C

Hurricane® S2 Turbine Ventilator

Applicable Product Codes (SKU)

Hurricane® 450mm	Hurricane® 500mm	Hurricane® 600mm
Custom 600672	Custom 600673	Custom 600674

Product Specifications (in exploded view)

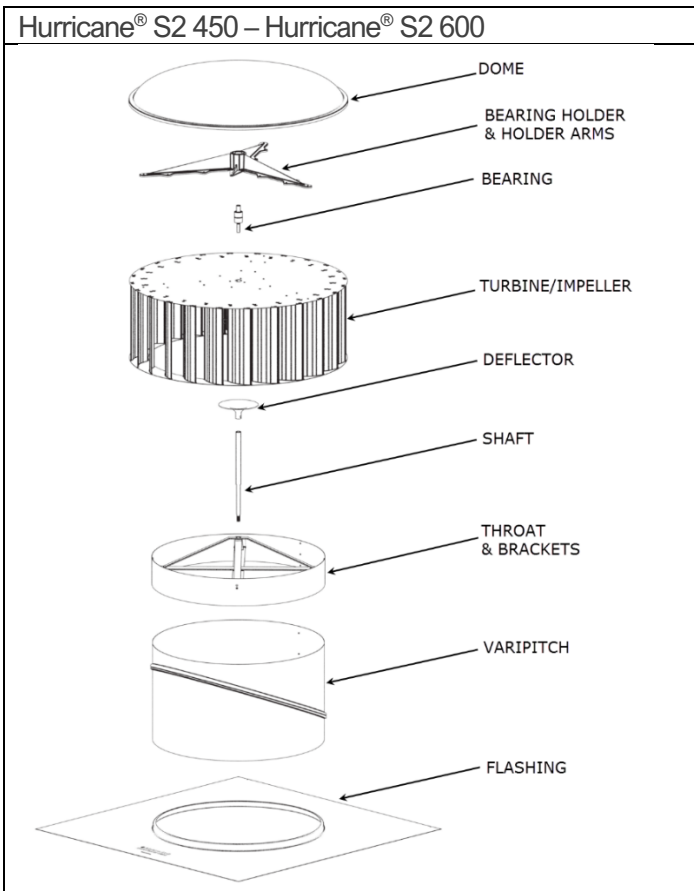

Product Information Summary S2 450 / S2 500 / S2 600

Ventilator Range	Hurricane® S2		
	S2 450	S2 500	S2 600
Ventilator Model	S2 450	S2 500	S2 600
Ventilator Type (AS/NZS 4740:2000 cl 1.5)	Type 4 – Rotating Wind-Driven Roof Ventilator		
Ventilator Performance Class (AS/NZS 4740:2000 Table 1.2)			
Effective Aerodynamic Area, EAA	0.108 m ²	0.137 m ²	0.165 m ²
Discharge Coefficient, C _d	0.764 - Class 1	0.780 - Class 1	0.639 - Class 2
Flow Coefficient, C _f	0.30 - Class 3	0.31 - Class 3	0.24 - Class 4
Nominal Performance* (m ³ /h)			
0 m/s	921 m ³ /h	1169 m ³ /h	1408 m ³ /h
3 m/s	988 m ³ /h	1259 m ³ /h	1475 m ³ /h
6 m/s	1165 m ³ /h	1497 m ³ /h	1660 m ³ /h

*In accordance to AS/NZS 4740:2000 nominal performance parameters where h = 6m, ΔT = 14°C, T = 20°C